

## LME-501-#

## Single channel pyroelectric detector

### Description:

single channel; TO39 housing; large chip size; low Micro; current mode;

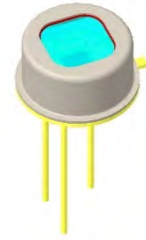

### Housing:

### Pin Assignment:

TO39 2+1Pin  
Bottom view

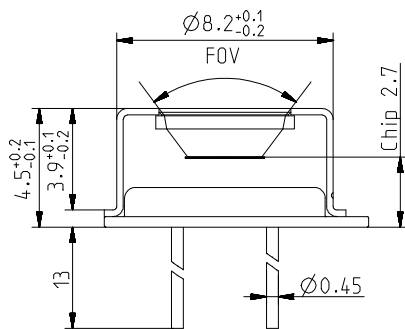
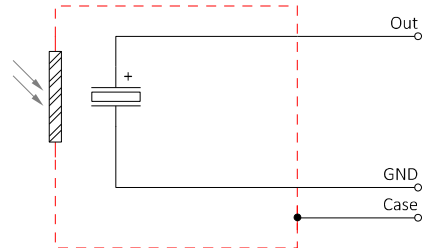
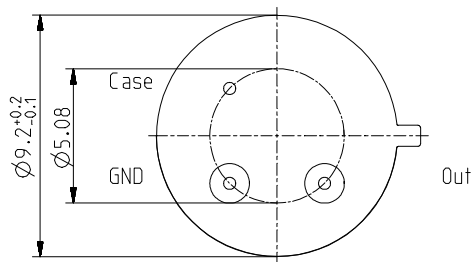

### Frequency Response:

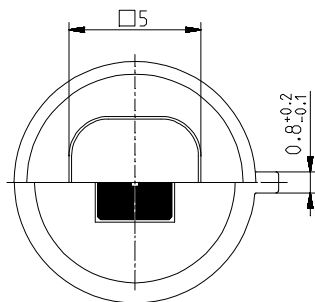
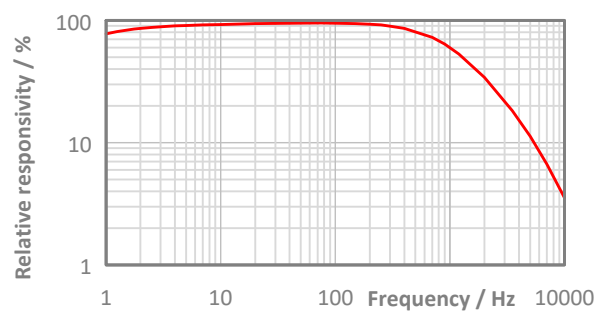

Top view



## LME-501-#

## Single channel pyroelectric detector

### Test Circuit:

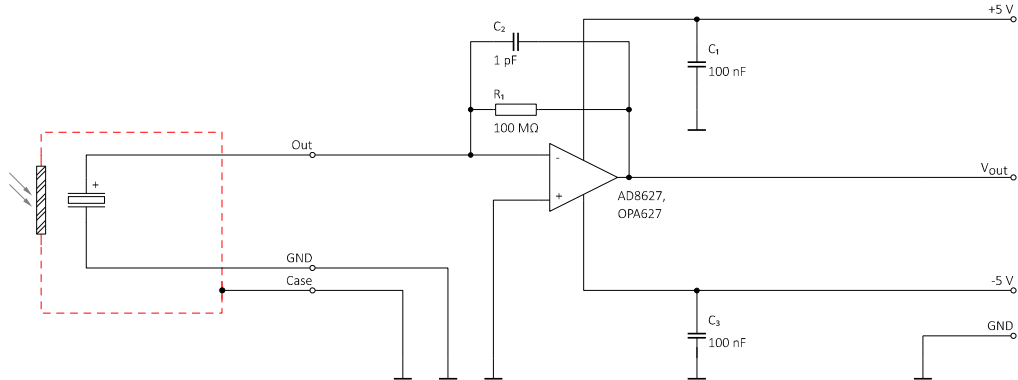

### Parameters:

Aperture size	nom	□ 5.0 mm
Element size / type	nom	3.0 × 3.0 mm <sup>2</sup> lithium-tantalate with black layer
Thermal time constant	typ	200 ms
Polarity	nom	Positive signal by positive IR flux change
Current responsivity (rms) {500 K, 10 Hz, 25 °C, without filter/window}	min	1.2 μA/W
Element capacitance {1 kHz, 1 V, 25 °C}	typ	120 pF
Element dielectric loss {1 kHz, 1 V, 25 °C}	max	0.001
Potential of detector case	nom	Selectable potential between -24 ... +24 V to Ground {EMC requires low-impedance coupling}
Operating / Storage temperature	nom	-40 ... +85 °C
IR filter		All InfraTec windows and filters are available (except KBr and CsI). Customized filters upon request.
Filter sizes	nom	Rectangular filters: (5.25 × 5.25) mm +0/-0.05 mm Circular filters: ø6.5 mm ±0.1 mm Standard thickness: 0.50 mm +0.2/-0.1 mm Thickness range 0.70 ... 1.10 mm on request
Field of View	min	CaF <sub>2</sub> or BaF <sub>2</sub> ; 0.4 mm thick: 60° Silicon substrate; 0.5 mm thick: 70°

InfraTec reserves the right to change these specifications at any time without notification.