

# PVIA-5-1×1-TO39-NW-36

## PRELIMINARY DATASHEET

### InAsSb room temperature optically immersed photovoltaic infrared detector



#### FEATURES

- Spectral range: 2.6 to 5.3  $\mu\text{m}$
- III-V material
- No minimum order quantity required

#### APPLICATIONS

- Gas detection ( $\text{CO}$ ,  $\text{CO}_2$ ,  $\text{NO}_x$ )
- Contactless temperature measurements

#### DETECTOR CONFIGURATION

Detector symbol	PVIA-5-1×1-TO39-NW-36
Detector type	photovoltaic
Active element material	epitaxial InAsSb heterostructure
Optical area, $A_o$	1 mm × 1 mm
Immersion	hyperhemisphere
Cooling	no
Detector package	TO39
Acceptance angle, $\Phi$	~36 deg.
Window	no

#### SPECIFICATION ( $T_{\text{chip}} = 293 \text{ K}$ , $V_b = 0 \text{ V}$ , unless otherwise noted)

Parameter	Test conditions / remarks	Value			Unit
		Min.	Typ.	Max.	
Active element temperature, $T_{\text{chip}}$	$T_{\text{amb}}$	-	293	-	K
Cut-on wavelength, $\lambda_{\text{cut-on}}$ (10%)	At 10% percent of peak responsivity	-	-	2.6	$\mu\text{m}$
Peak wavelength, $\lambda_{\text{peak}}$		-	4.5	-	$\mu\text{m}$
Cut-off wavelength, $\lambda_{\text{cut-off}}$ (10%)	At 10% percent of peak responsivity	5.3	-	-	$\mu\text{m}$
Detectivity, $D^*$	At $\lambda_{\text{peak}}$ , $f = 20 \text{ kHz}$	$5.0 \times 10^9$	-	-	$\text{cm}\cdot\text{Hz}^{0.5}/\text{W}$
Current responsivity, $R_i$	At $\lambda_{\text{peak}}$	1.2	-	-	A/W
Time constant, $\tau$		-	-	15	ns
Resistance, $R$		70	-	-	$\Omega$

#### SPECTRAL RESPONSE (Typ., $T_{\text{chip}} = 293 \text{ K}$ )

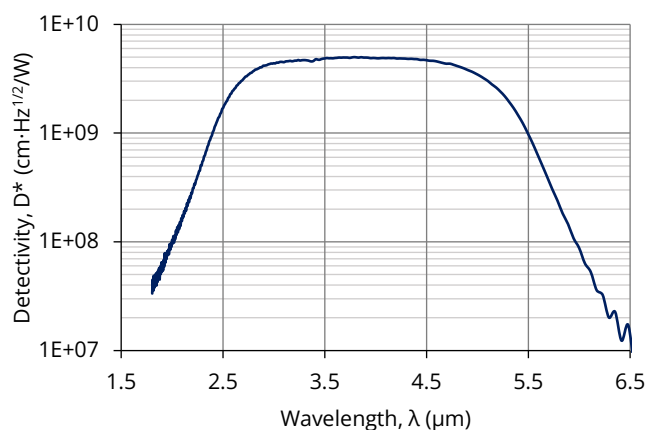

## MECHANICAL LAYOUT AND PINOUT (Unit: mm)

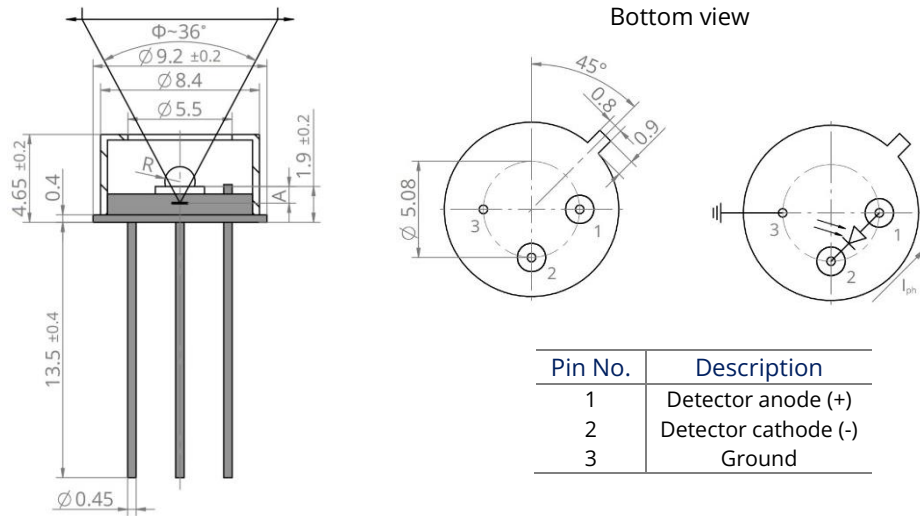

$\Phi$  – acceptance angle

R = 0.8 mm (hyperhemisphere microlens radius)

A – distance from the bottom of the immersion lens to the focal plane

## ABSOLUTE MAXIMUM RATINGS

Parameter	Test conditions / remarks	Value	Unit
Maximum incident optical power density	Continuous wave (CW) or single pulses >1 $\mu$ s duration	2.5	W/cm <sup>2</sup>
	Single pulses <1 $\mu$ s duration	10	kW/cm <sup>2</sup>
Soldering temperature	Within 5 s or less	$\leq 370$	$^{\circ}$ C
Ambient operating temperature T <sub>amb</sub>		-20 to 70	$^{\circ}$ C
Storage temperature T <sub>stg</sub>		-20 to 85	$^{\circ}$ C
Storage humidity	No dew condensation	10 to 90	%

Stresses beyond those listed under Absolute Maximum Ratings may cause permanent damage to the device.

Constant or repeated exposure to absolute maximum rating conditions may affect the quality and reliability of the device.