

LRM-274-#

PYROMID® multi channel pyroelectric detector

Description:

quad channel; TO8 housing; medium chip size; thermal compensation; OpAmp; single supply; current mode; feedback 100 GOhm;

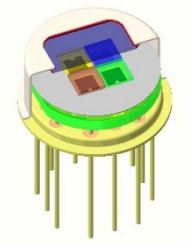

Housing:

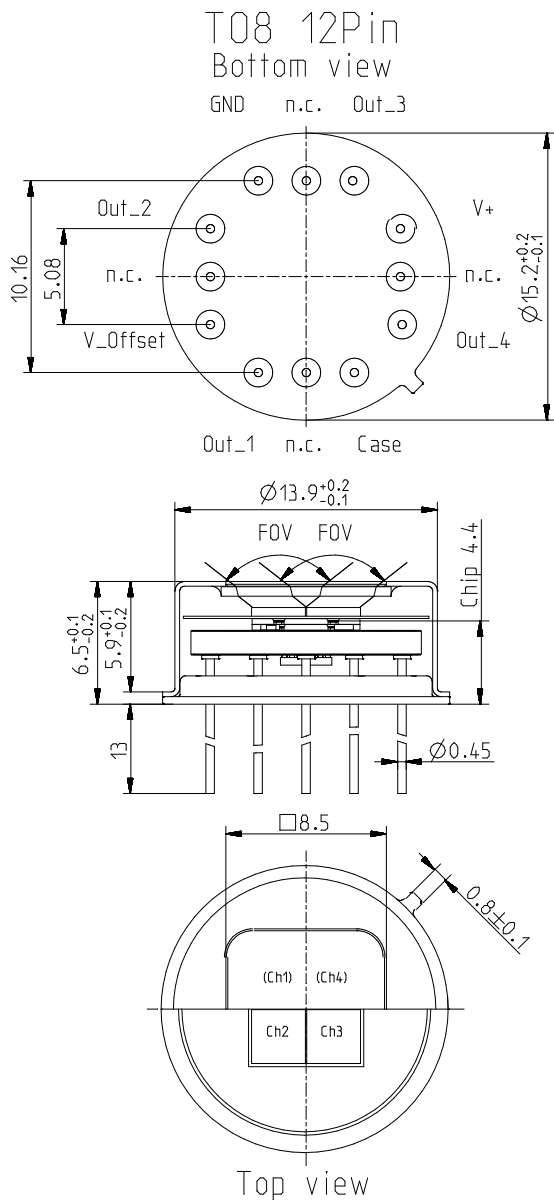

Maximum current between Case and the "Case"-Pin 10 mA!

Pin Assignment:

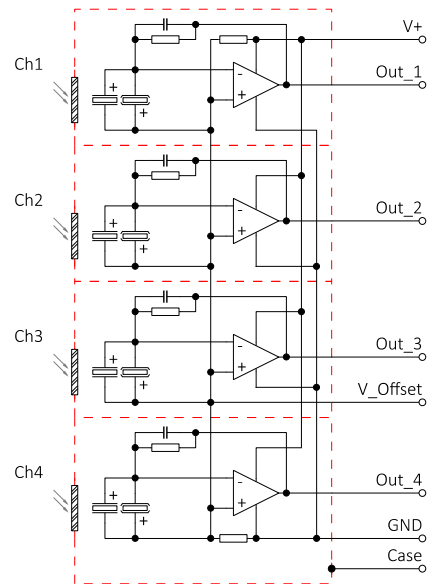

Frequency Response:

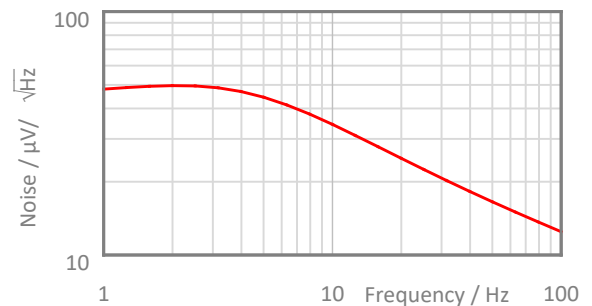
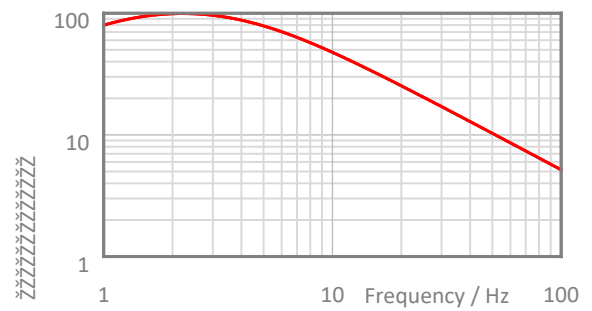

LRM-274-#

PYROMID® multi channel pyroelectric detector

Test Circuit:

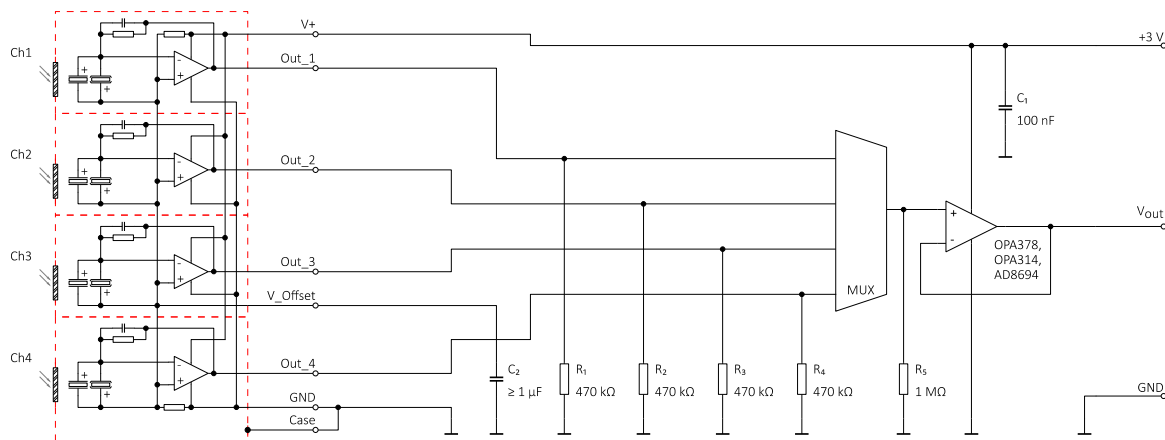

Parameters:

Aperture size	nom	□ 8.5 mm
Element size / type	nom	2.0 × 2.0 mm ² lithium-tantalate with black layer
Thermal time constant	typ	150 ms
Feedback resistor	nom	100 GΩ ±20 %
Feedback capacitor	nom	0.3 pF ±0.1 pF
Polarity	nom	Negative signal by positive IR flux change
Voltage responsivity (rms) {500 K, 10 Hz, 25 °C, without filter/window}	min	65,000 V/W
Noise density (rms) {10 Hz, BW 1 Hz, 25 °C}	max	45 μV/√Hz
Detectivity {500 K, 10 Hz, BW 1 Hz, 25 °C, without filter/window}	typ	6.0E+08 cmVHz/W
CMOS operational amplifier	nom	OpAmp4
Operating supply voltage V+		2.7 ... 5.0 V
Recommended supply voltage V+	nom	V+ = +3 V
Supply current {output load 1 MΩ}	max	900 μA
Offset voltage {25 °C; output load 1 MΩ}		V+/2 ±10%
Internal Voffset (with load resistance > 1 MOhm)		V+/2 ±10 %
Recommended impedance for control of Voffset		10 kΩ
Optimal output load	nom	470 kΩ
Absolute output current	max	1 mA
Operating / Storage temperature	nom	-25 ... +85 °C
IR filter		Combinations of all InfraTec standard narrow band pass filters are available. Customized filters upon request.
Filter sizes	nom	Rectangular filters: (2.85 × 2.85) mm ±0.1 mm Circular filters: not applicable Standard thickness: 0.50 mm +0.2/-0.1 mm Thickness range 0.70 ... 1.10 mm on request
Aperture window		Selected by InfraTec for best channel filter matching
Aperture window sizes	nom	Rectangular filters: (9.00 × 9.00) mm ±0.05 mm Circular filters: not applicable Standard thickness: 0.50 mm ±0.1 mm
Field of View	min	110° (with filter: silicon substrate; 0.5 mm thick and aperture: Si ARC; 0.5 mm thick)

This preliminary datasheet contains information regarding a product InfraTec is considering for production release. Due to this state all data are for information only. InfraTec reserves the right to change these specifications at any time without notification.