

UM-10.6

2 – 12 μm and DC – 70 MHz HgCdTe universal IR detection module with photovoltaic multiple junction detector

UM-10.6 is an universal „all-in-one“ IR detection module. Thermoelectrically cooled photovoltaic detector, based on HgCdTe heterostructure, is integrated with transimpedance, DC coupled preamplifier, a fan and a thermoelectric cooler controller in a compact housing. 3° wedged zinc selenide anti-reflection coated window prevents unwanted interference effects. UM-10.6 detection module is very convenient and user-friendly device, thus can be easily used in a variety of LWIR applications.

Spectral response ($T_a = 20^\circ\text{C}$)

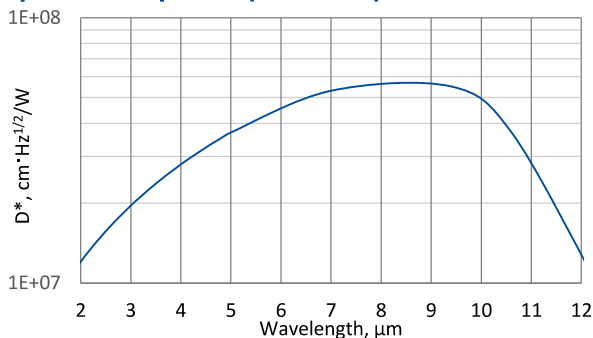

Exemplary spectral detectivity, the spectral response of delivered devices may differ.



Specification ($T_a = 20^\circ\text{C}$)

Parameter	Typical value
Optical parameters	
Cut-on wavelength $\lambda_{\text{cut-on}}$ (10%), μm	≤ 2.0
Peak wavelength λ_{peak} , μm	9.3 ± 2.0
Optimum wavelength λ_{opt} , μm	10.6
Cut-off wavelength $\lambda_{\text{cut-off}}$ (10%), μm	≥ 12.0
Detectivity $D^*(\lambda_{\text{peak}})$, $\text{cm}\cdot\text{Hz}^{1/2}/\text{W}$	$\geq 5.0 \times 10^7$
Detectivity $D^*(\lambda_{\text{opt}})$, $\text{cm}\cdot\text{Hz}^{1/2}/\text{W}$	$\geq 4.0 \times 10^7$
Output noise density v_n (averaged over 1 MHz to f_{hi}), $\text{nV}/\text{Hz}^{1/2}$	≤ 380
Electrical parameters	
Voltage responsivity $R_v(\lambda_{\text{peak}})$, V/W	$\geq 1.6 \times 10^2$
Voltage responsivity $R_v(\lambda_{\text{opt}})$, V/W	$\geq 1.0 \times 10^2$
Low cut-off frequency f_{lo} , Hz	DC
High cut-off frequency f_{hi} , Hz	$\geq 70\text{M}$
Output impedance R_{out} , Ω	50
Output voltage swing V_{out} , V	± 2 ($R_L = 1 \text{ M}\Omega^*)$)
Output voltage offset V_{off} , mV	max ± 20
Power supply voltage V_{sup} , V	+5
DC monitor (approx. 0 V offset)	
Voltage responsivity $R_v(\lambda_{\text{peak}})$, V/W	$\geq 3.6 \times 10^1$
Voltage responsivity $R_v(\lambda_{\text{opt}})$, V/W	$\geq 2.4 \times 10^1$
Low cut-off frequency f_{lo} , Hz	DC
High cut-off frequency f_{hi} , Hz	150k
Other information	
Active element material	epitaxial HgCdTe heterostructure
Active area A , $\text{mm} \times \text{mm}$	1x1
Window	wedged zinc selenide AR coated (wZnSeAR)
Acceptance angle Φ	$\sim 70^\circ$
Ambient operating temperature T_a , $^\circ\text{C}$	10 to 30
Signal output socket	SMA
DC monitor socket	SMA
Power supply socket	DC 2.5/5.5
Mounting hole	M4
Fan	yes

* R_L – load resistance

Features

- Integrated TEC controller and fan
- Single power supply
- DC monitor
- Sensitive to IR radiation polarisation
- Optimised for effective heat dissipation
- Compatible with optical accessories
- Cost effective OEM version available
- Universal and flexible
- Quantity discounted price
- Fast delivery

Applications

- Gas detection, monitoring and analysis
- CO_2 laser (10.6 μm) measurements
- Laser power monitoring and control
- Laser beam profiling and positioning
- Laser calibration

Mechanical layout, mm

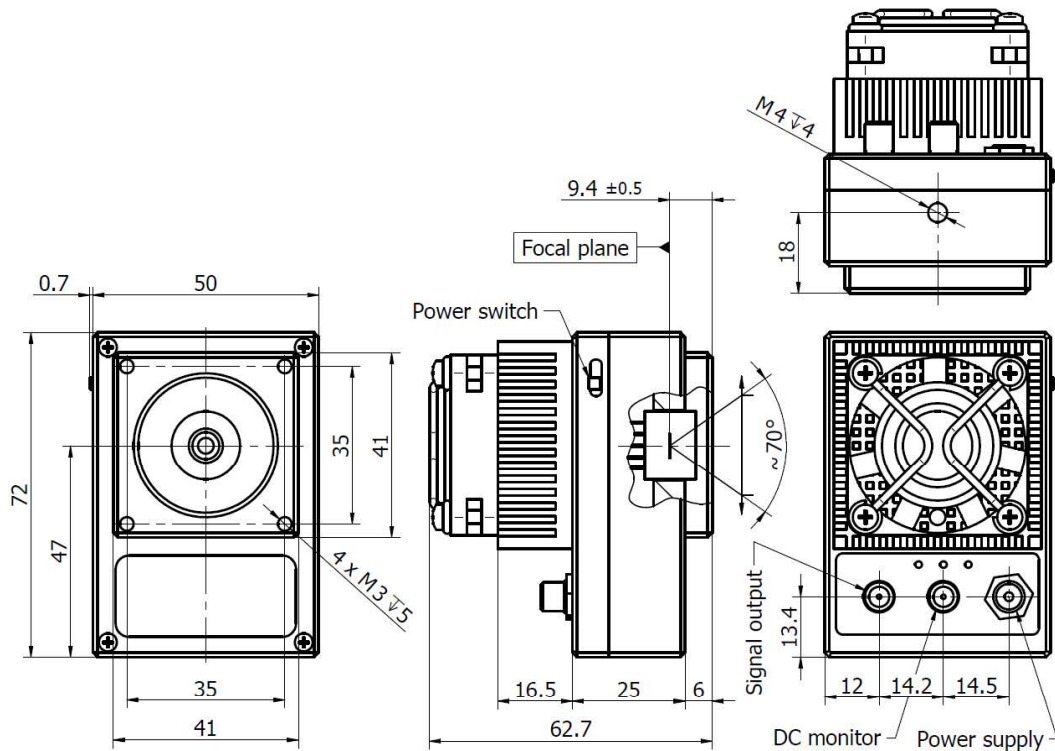

Schematic diagram

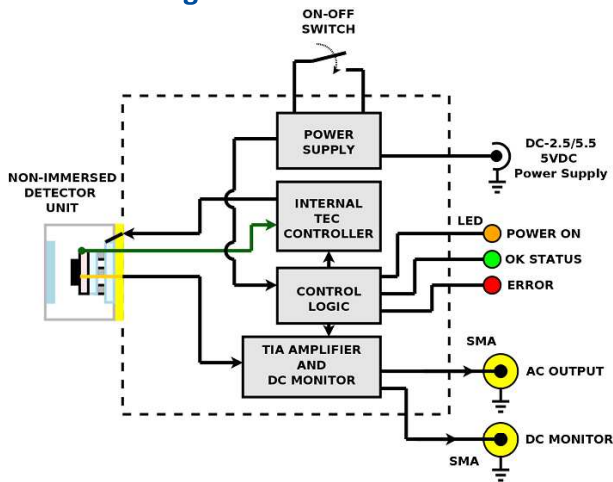

Spectral transmission of wZnSeAR window (typical example)

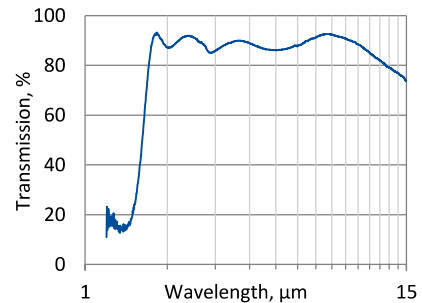

Included accessories

- 2x SMA-BNC cables + AC adaptor

Dedicated accessories

- [OTA](#) optical threaded adapter
- [DRB-2](#) base mounting system