

PVMI-3TE series

2 – 13 μm HgCdTe three-stage thermoelectrically cooled, optically immersed photovoltaic multiple junction detectors

PVMI-3TE series features three-stage thermoelectrically cooled IR photovoltaic multiple junction detectors based on sophisticated HgCdTe heterostructures for the best performance and stability, optically immersed in order to improve parameters of the devices. The detectors are optimized for the maximum performance at λ_{opt} . They are especially useful as large optical area detectors operating within 2 to 12 μm spectral range. 3° wedged zinc selenide anti-reflection coated (wZnSeAR) window prevents unwanted interference effects.

Spectral response ($T_a = 20^\circ\text{C}$)

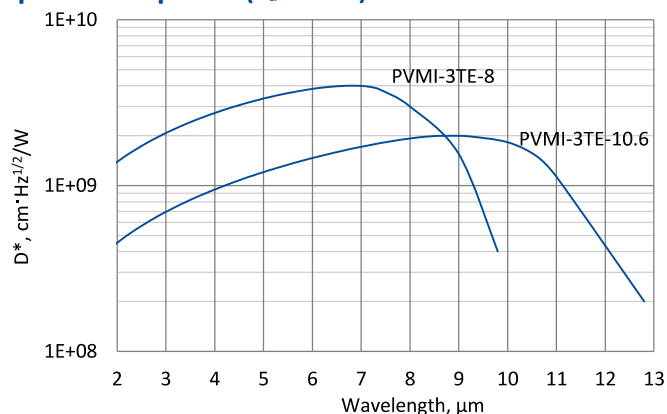

Exemplary spectral detectivity, the spectral response of delivered devices may differ.

Specification ($T_a = 20^\circ\text{C}$)

Parameter	Detector type	
	PVMI-3TE-8	PVMI-3TE-10.6
Active element material	epitaxial HgCdTe heterostructure	
Optimal wavelength λ_{opt} , μm	8.0	10.6
Detectivity $D^*(\lambda_{peak})$, $\text{cm}\cdot\text{Hz}^{1/2}/\text{W}$	$\geq 4.0 \times 10^9$	$\geq 2.0 \times 10^9$
Detectivity $D^*(\lambda_{opt})$, $\text{cm}\cdot\text{Hz}^{1/2}/\text{W}$	$\geq 3.0 \times 10^9$	$\geq 1.5 \times 10^9$
Current responsivity $R_i(\lambda_{opt})$, A/W	≥ 0.15	≥ 0.10
Time constant τ , ns	≤ 4	≤ 3
Resistance R , Ω	200 to 1500	100 to 400
Active element temperature T_{det} , K	~ 210	
Optical area A_O , mm×mm	1×1	
Package	TO8, TO66	
Acceptance angle Φ	$\sim 36^\circ$	
Window	wZnSeAR	

Three-stage thermoelectric cooler parameters

Parameter	Value
T_{det} , K	~ 210
V_{max} , V	3.6
I_{max} , A	0.45
Q_{max} , W	0.27

Thermistor characteristics

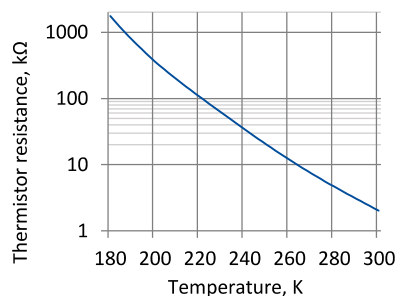

Spectral transmission of wZnSeAR window (typical example)

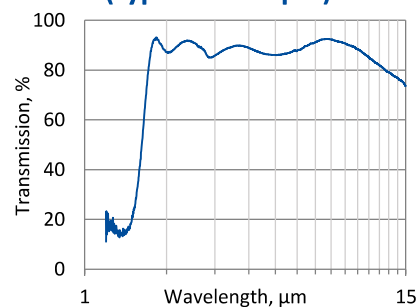

Mechanical layout, mm

3TE-T08 package

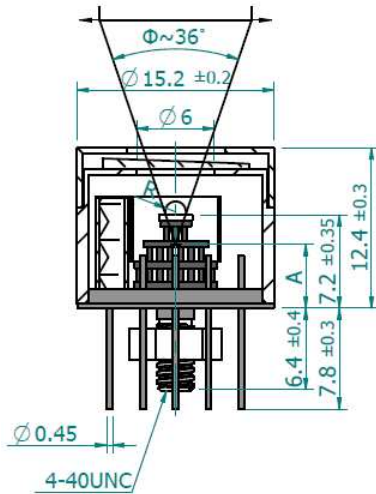

Parameter	Value
Immersion microlens shape	hyperhemisphere
Optical area A_0 , mm×mm	1×1
R, mm	0.8
A, mm	4,8±0,35

Φ – acceptance angle
 R – hyperhemisphere microlens radius
 A – distance from the bottom of 3TE-T08 header to the focal plane

Bottom view

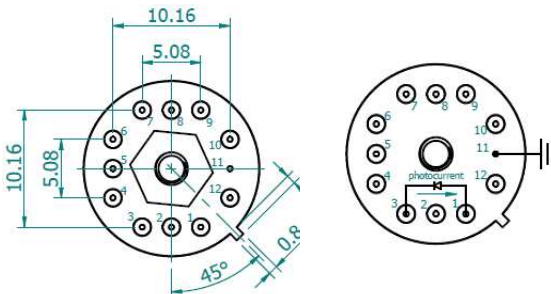

Function	Pin number
Detector	1, 3
Thermistor	7, 9
TE cooler supply	2(+), 8(-)
Chassis ground	11
Not used	4, 5, 6, 10, 12

3TE-T066 package

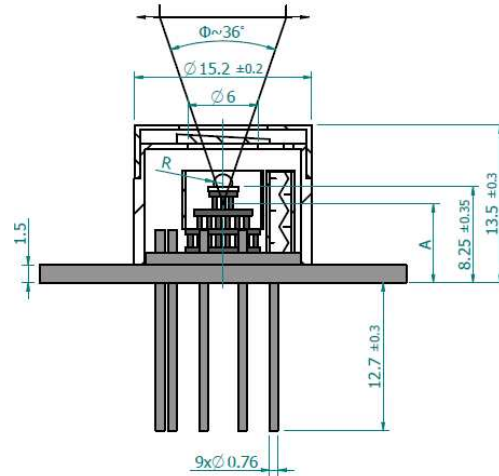

Parameter	Value
Immersion microlens shape	hyperhemisphere
Optical area A_0 , mm×mm	1×1
R, mm	0.8
A, mm	5,85±0,35

Φ – acceptance angle
 R – hyperhemisphere microlens radius
 A – distance from the bottom of 3TE-T066 header to the focal plane

Top view

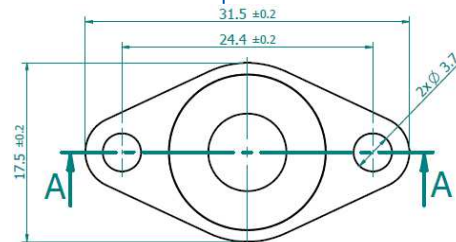

Bottom view

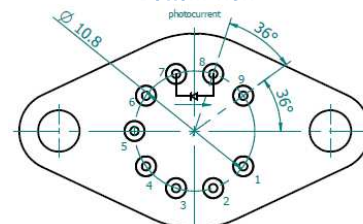

Function	Pin number
Detector	7, 8
Thermistor	5, 6
TE cooler supply	1(+), 9(-)
Not used	2, 3, 4

Dedicated preamplifiers



„all-in-one“ AIP



programmable PIP



standard MIP

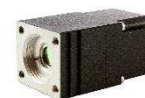

small SIP-T08