

## PVI-4TE series

### 2 – 12 μm HgCdTe four-stage thermoelectrically cooled, optically immersed photovoltaic detectors

**PVI-4TE series** features four-stage thermoelectrically cooled IR photovoltaic detectors based on sophisticated HgCdTe heterostructures for the best performance and stability, optically immersed in order to improve parameters of the devices. The detectors are optimized for the maximum performance at  $\lambda_{opt}$ . Cut-on wavelength can be optimized upon request. Reverse bias may significantly increase speed of response and dynamic range. It results also in improved performance at high frequencies, but 1/f noise that appears in biased devices may reduce performance at low frequencies. 3° wedged sapphire (wAl<sub>2</sub>O<sub>3</sub>) or zinc selenide anti-reflection coated (wZnSeAR) window prevents unwanted interference effects.

#### Spectral response ( $T_a = 20^\circ\text{C}$ , $V_b = 0\text{ mV}$ )

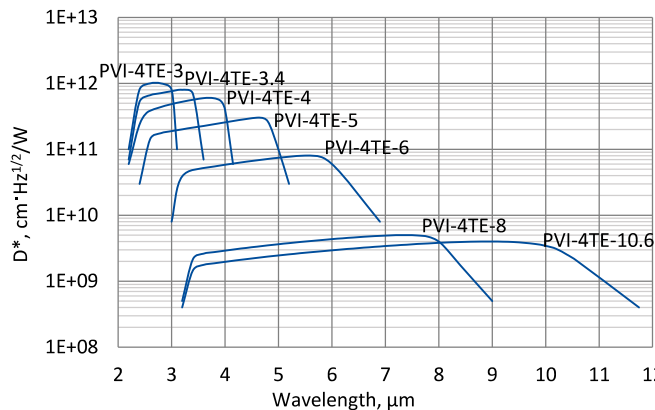

Exemplary spectral detectivity, the spectral response of delivered devices may differ.

#### Specification ( $T_a = 20^\circ\text{C}$ , $V_b = 0\text{V}$ )

Parameter	Detector type						
	PVI-4TE-3	PVI-4TE-3.4	PVI-4TE-4	PVI-4TE-5	PVI-4TE-6	PVI-4TE-8	PVI-4TE-10.6
Active element material	epitaxial HgCdTe heterostructure						
Optimum wavelength $\lambda_{opt}$ , μm	3.0	3.4	4.0	5.0	6.0	8.0	10.6
Detectivity $D^*(\lambda_{peak})$ , $\text{cm}^2\cdot\text{Hz}^{1/2}/\text{W}$	$\geq 1.0 \times 10^{12}$	$\geq 8.0 \times 10^{11}$	$\geq 6.0 \times 10^{11}$	$\geq 3.0 \times 10^{11}$	$\geq 8.0 \times 10^{10}$	$\geq 5.0 \times 10^9$	$\geq 4.0 \times 10^9$
Detectivity $D^*(\lambda_{opt})$ , $\text{cm}^2\cdot\text{Hz}^{1/2}/\text{W}$	$\geq 8.0 \times 10^{11}$	$\geq 7.0 \times 10^{11}$	$\geq 4.0 \times 10^{11}$	$\geq 1.0 \times 10^{11}$	$\geq 6.0 \times 10^{10}$	$\geq 4.0 \times 10^9$	$\geq 2.0 \times 10^9$
Current responsivity $R_i(\lambda_{opt})$ , A/W	$\geq 0.5$	$\geq 0.8$	$\geq 1.0$	$\geq 1.3$	$\geq 1.5$		$\geq 0.5$
Time constant $\tau$ , ns	$\leq 280$	$\leq 200$	$\leq 100$	$\leq 80$	$\leq 50$	$\leq 45$	$\leq 25$
Resistance-optical area product $R \cdot A_o$ , $\Omega \cdot \text{cm}^2$	$\geq 30000$	$\geq 2000$	$\geq 800$	$\geq 40$	$\geq 3$	$\geq 0.06$	$\geq 0.05$
Active element temperature $T_{det}$ , K	~195						
Optical area $A_o$ , mm×mm	0.5×0.5, 1×1						
Package	TO8, TO66						
Acceptance angle $\Phi$	~36°						
Window	wAl <sub>2</sub> O <sub>3</sub>				wZnSeAR		

#### Four-stage thermoelectric cooler parameters

Parameter	Value
$T_{det}$ , K	~195
$V_{max}$ , V	8.3
$I_{max}$ , A	0.4
$Q_{max}$ , W	0.28

#### Thermistor characteristics

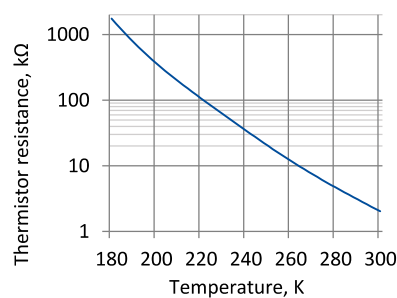

#### Spectral transmission of wAl<sub>2</sub>O<sub>3</sub> and wZnSeAR windows (typical example)

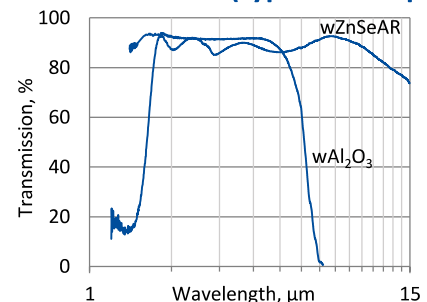

### Mechanical layout, mm

#### 4TE-T08 package

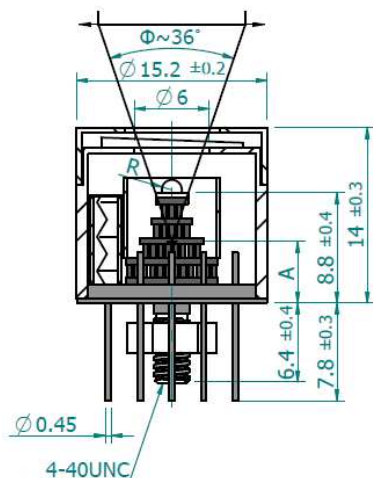

Parameter	Value
Immersion microlens shape	hyperhemisphere
Optical area $A_0$ , mm×mm	0,5×0,5    1×1
R, mm	0,5    0,8
A, mm	7,3±0,4    6,4±0,4

Φ – acceptance angle  
 R – hyperhemisphere microlens radius  
 A – distance from the bottom of 4TE-T08 header to the focal plane

#### Bottom view

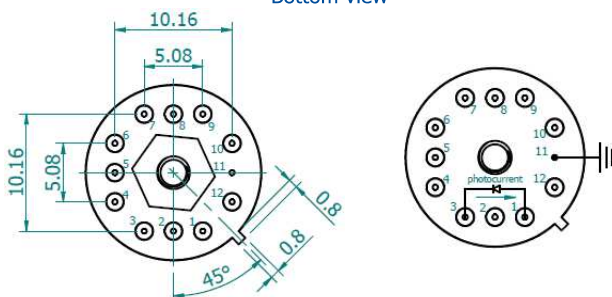

Function	Pin number
Detector	1, 3
Reverse bias (optional)	1(-), 3(+)
Thermistor	7, 9
TE cooler supply	2(+), 8(-)
Chassis ground	11
Not used	4, 5, 6, 10, 12

#### 4TE-T066 package

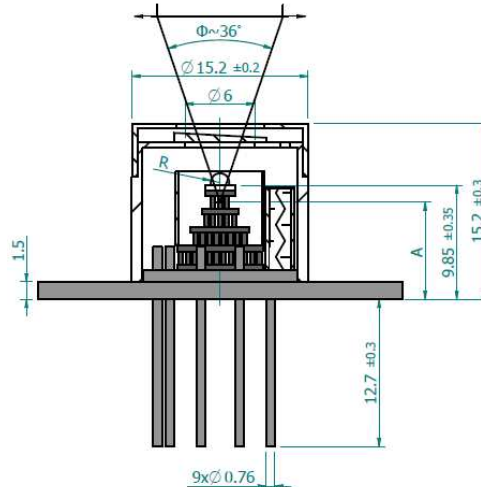

Parameter	Value
Immersion microlens shape	hyperhemisphere
Optical area $A_0$ , mm×mm	0,5×0,5    1×1
R, mm	0,5    0,8
A, mm	8,35±0,40    7,45±0,40

Φ – acceptance angle  
 R – hyperhemisphere microlens radius  
 A – distance from the bottom of 4TE-T066 header to the focal plane

#### Top view

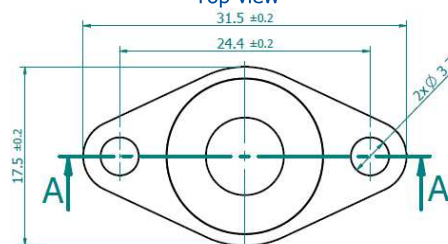

#### Bottom view

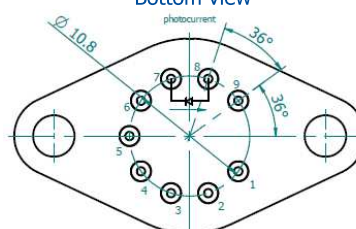

Function	Pin number
Detector	7, 8
Reverse bias (optional)	7(+), 8(-)
Thermistor	5, 6
TE cooler supply	1(+), 9(-)
Not used	2, 3, 4

### Dedicated preamplifiers



„all-in-one“ AIP



programmable PIP



standard MIP



small SIP-T08



fast FIP