

PVI-2TE series

2 – 12 μm HgCdTe two-stage thermoelectrically cooled, optically immersed photovoltaic detectors

PVI-2TE series features two-stage thermoelectrically cooled IR photovoltaic detectors based on sophisticated HgCdTe heterostructures for the best performance and stability, optically immersed in order to improve parameters of the devices. The detectors are optimized for the maximum performance at λ_{opt} . Cut-on wavelength can be optimized upon request. Reverse bias may significantly increase speed of response and dynamic range. It results also in improved performance at high frequencies, but 1/f noise that appears in biased devices may reduce performance at low frequencies. 3° wedged sapphire (wAl₂O₃) or zinc selenide anti-reflection coated (wZnSeAR) window prevents unwanted interference effects.

Spectral response ($T_a = 20^\circ\text{C}$, $V_b = 0\text{ mV}$)

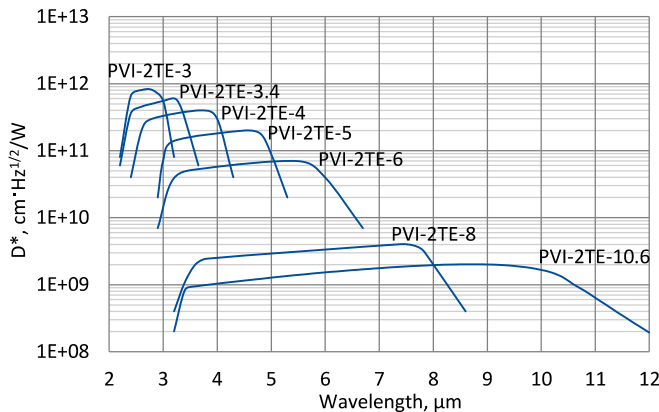

Exemplary spectral detectivity, the spectral response of delivered devices may differ.

Specification ($T_a = 20^\circ\text{C}$, $V_b = 0\text{ V}$)

Parameter	Detector type						
	PVI-2TE-3	PVI-2TE-3.4	PVI-2TE-4	PVI-2TE-5	PVI-2TE-6	PVI-2TE-8	PVI-2TE-10.6
Active element material	epitaxial HgCdTe heterostructure						
Optimum wavelength λ_{opt} , μm	3.0	3.4	4.0	5.0	6.0	8.0	10.6
Detectivity $D^*(\lambda_{peak})$, cm ² ·Hz ^{1/2} /W	$\geq 8.0 \times 10^{11}$	$\geq 6.0 \times 10^{11}$	$\geq 4.0 \times 10^{11}$	$\geq 2.0 \times 10^{11}$	$\geq 7.0 \times 10^{10}$	$\geq 4.0 \times 10^9$	$\geq 2.0 \times 10^9$
Detectivity $D^*(\lambda_{opt})$, cm ² ·Hz ^{1/2} /W	$\geq 5.5 \times 10^{11}$	$\geq 3.0 \times 10^{11}$	$\geq 3.0 \times 10^{11}$	$\geq 9.0 \times 10^{10}$	$\geq 4.0 \times 10^{10}$	$\geq 2.0 \times 10^9$	$\geq 1.0 \times 10^9$
Current responsivity $R_i(\lambda_{opt})$, A/W	≥ 0.5	≥ 0.8	≥ 1.3	≥ 1.3	≥ 1.5	≥ 0.8	≥ 0.4
Time constant τ , ns	≤ 280	≤ 200	≤ 100	≤ 80	≤ 50	≤ 45	≤ 10
Resistance-optical area product $R \cdot A_o$, $\Omega \cdot \text{cm}^2$	≥ 15000	≥ 300	≥ 200	≥ 10	≥ 2	≥ 0.02	≥ 0.01
Active element temperature T_{det} , K	~230						
Optical area A_o , mm \times mm	0.5 \times 0.5, 1 \times 1						0.5 \times 0.5
Package	TO8, TO66						
Acceptance angle Φ	~36°						
Window	wAl ₂ O ₃				wZnSeAR		

Two-stage thermoelectric cooler parameters

Parameter	Value
T_{det} , K	~230
V_{max} , V	1.3
I_{max} , A	1.2
Q_{max} , W	0.36

Thermistor characteristics

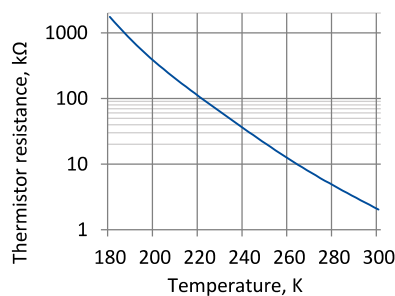

Spectral transmission of wAl₂O₃ and wZnSeAR windows (typical example)

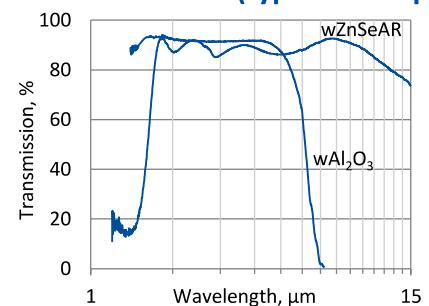

Mechanical layout, mm

2TE-T08 package

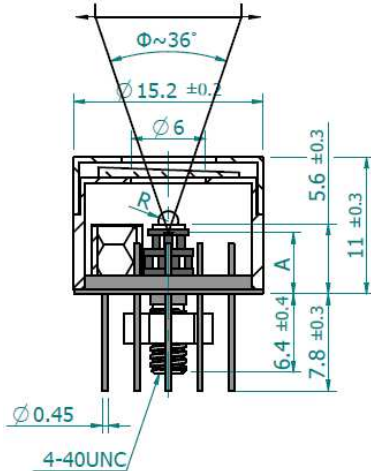

Parameter	Value
Immersion microlens shape	hyperhemisphere
Optical area A_0 , mm×mm	0.5×0.5 1×1
R, mm	0.5 0.8
A, mm	4.1±0.3 3.2±0.3

Φ – acceptance angle
 R – hyperhemisphere microlens radius
 A – distance from the bottom of 2TE-T08 header to the focal plane

Bottom view

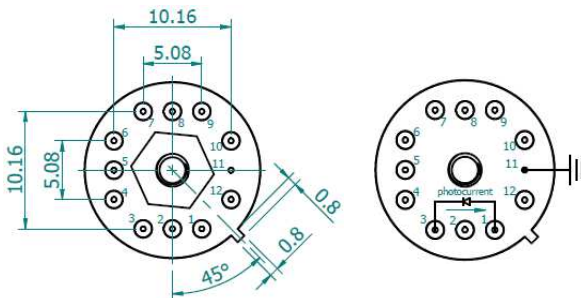

Function	Pin number
Detector	1, 3
Reverse bias (optional)	1(-), 3(+)
Thermistor	7, 9
TE cooler supply	2(+), 8(-)
Chassis ground	11
Not used	4, 5, 6, 10, 12

2TE-T066 package

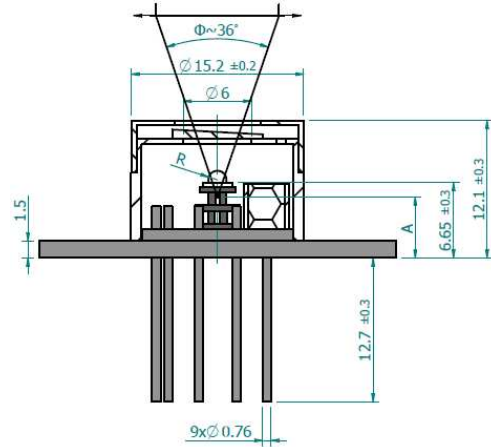

Parameter	Value
Immersion microlens shape	hyperhemisphere
Optical area A_0 , mm×mm	0.5×0.5 1×1
R, mm	0.5 0.8
A, mm	5.15±0.30 3.2±0.3

Φ – acceptance angle
 R – hyperhemisphere microlens radius
 A – distance from the bottom of 2TE-T066 header to the focal plane

Top view

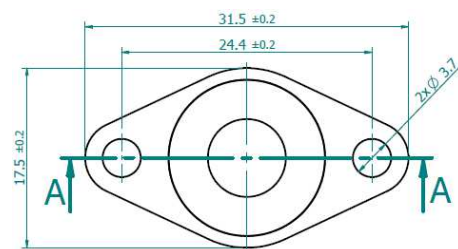

Bottom view

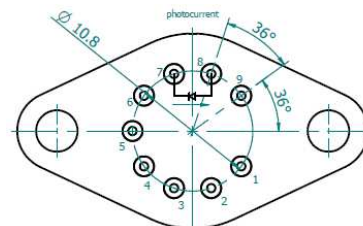

Function	Pin number
Detector	7, 8
Reverse bias (optional)	7(+), 8(-)
Thermistor	5, 6
TE cooler supply	1(+), 9(-)
Not used	2, 3, 4

Dedicated preamplifiers



„all-in-one“ AIP



programmable PIP



standard MIP



small SIP-T08



fast FIP