

PV-3TE series

2 – 12 μm HgCdTe three-stage thermoelectrically cooled photovoltaic detectors

PV-3TE series features three-stage thermoelectrically cooled IR photovoltaic detectors based on sophisticated HgCdTe heterostructures for the best performance and stability. The devices are optimized for the maximum performance at λ_{opt} . Cut-on wavelength can be optimized upon request. Reverse bias may significantly increase response speed and dynamic range. It also results in improved performance at high frequencies, but 1/f noise that appears in biased devices may reduce performance at low frequencies. 3° wedged sapphire (wAl₂O₃) or zinc selenide anti-reflection coated (wZnSeAR) window prevents unwanted interference effects.

Spectral response ($T_a = 20^\circ\text{C}$, $V_b = 0\text{ mV}$)

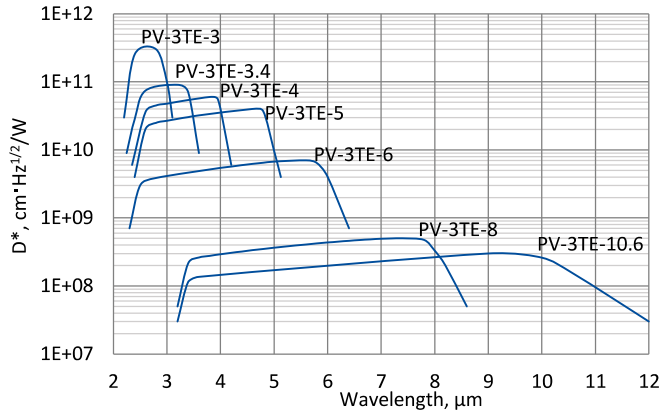

Exemplary spectral detectivity, the spectral response of delivered devices may differ.

Specification ($T_a = 20^\circ\text{C}$, $V_b = 0\text{V}$)

Parameter	Detector type						
	PV-3TE-3	PV-3TE-3.4	PV-3TE-4	PV-3TE-5	PV-3TE-6	PV-3TE-8	PV-3TE-10.6
Active element material	epitaxial HgCdTe heterostructure						
Optimum wavelength λ_{opt} , μm	3.0	3.4	4.0	5.0	6.0	8.0	10.6
Detectivity $D^*(\lambda_{peak})$, $\text{cm}^2 \cdot \text{Hz}^{1/2} / \text{W}$	$\geq 3.0 \times 10^{11}$	$\geq 9.0 \times 10^{10}$	$\geq 6.0 \times 10^{10}$	$\geq 4.0 \times 10^{10}$	$\geq 7.0 \times 10^9$	$\geq 5.0 \times 10^8$	$\geq 3.0 \times 10^8$
Detectivity $D^*(\lambda_{opt})$, $\text{cm}^2 \cdot \text{Hz}^{1/2} / \text{W}$	$\geq 1.0 \times 10^{11}$	$\geq 7.0 \times 10^{10}$	$\geq 4.0 \times 10^{10}$	$\geq 1.0 \times 10^{10}$	$\geq 4.0 \times 10^9$	$\geq 3.0 \times 10^8$	$\geq 1.5 \times 10^8$
Current responsivity $R_i(\lambda_{opt})$, A/W	≥ 0.5	≥ 0.8	≥ 1.0	≥ 1.3	≥ 1.5	≥ 1.0	≥ 0.7
Time constant τ , ns	≤ 280	≤ 200	≤ 100	≤ 80	≤ 50	≤ 45	≤ 10
Resistance-active area product $R \cdot A$, $\Omega \cdot \text{cm}^2$	≥ 240	≥ 15	≥ 6	≥ 0.3	≥ 0.025	≥ 0.0004	≥ 0.0002
Active element temperature T_{det} , K	~ 210						
Active area A , $\text{mm} \times \text{mm}$	0.05 \times 0.05			0.1 \times 0.1		0.05 \times 0.05	
Package	TO8, TO66						
Acceptance angle Φ	$\sim 70^\circ$						
Window	wAl ₂ O ₃				wZnSeAR		

Three-stage thermoelectric cooler parameters

Parameter	Value
T_{det} , K	~ 210
V_{max} , V	3.6
I_{max} , A	0.45
Q_{max} , W	0.27

Thermistor characteristics

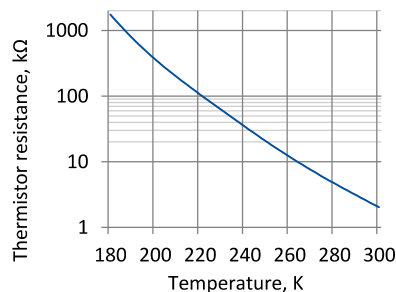

Spectral transmission of wAl₂O₃ and wZnSeAR windows (typical example)

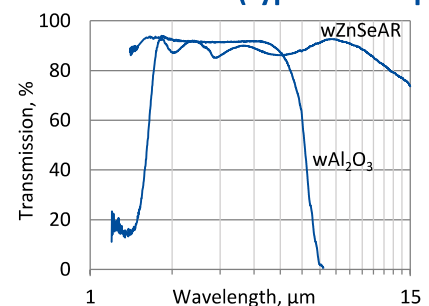

Mechanical layout, mm

3TE-TO8 package

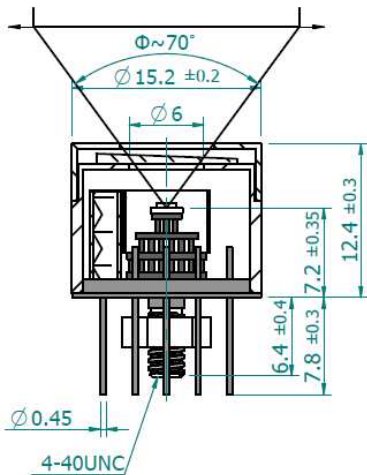

Φ – acceptance angle

Bottom view

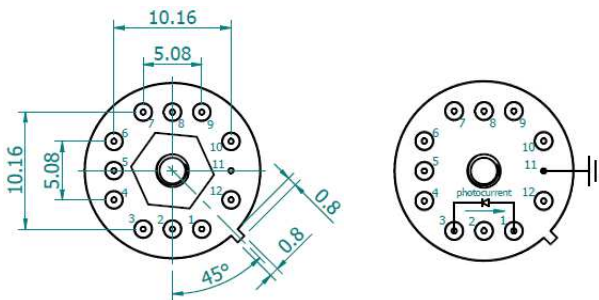

Function	Pin number
Detector	1, 3
Reverse bias (optional)	1(-), 3(+)
Thermistor	7, 9
TE cooler supply	2(+), 8(-)
Chassis ground	11
Not used	4, 5, 6, 10, 12

3TE-TO66 package

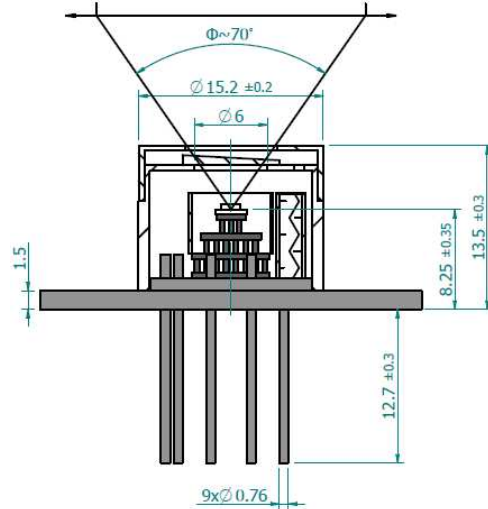

Φ – acceptance angle

Top view

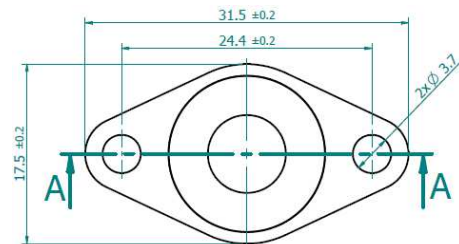

Bottom view

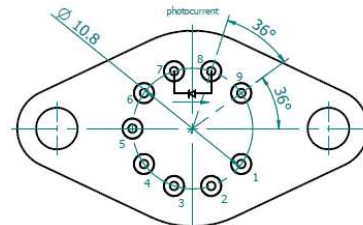

Function	Pin number
Detector	7, 8
Reverse bias (optional)	7(+), 8(-)
Thermistor	5, 6
TE cooler supply	1(+), 9(-)
Not used	2, 3, 4

Dedicated preamplifiers



„all-in-one“ AIP



programmable PIP



standard MIP



small SIP-TO8



fast FIP