

PEM-10.6-2x2-PEM-SMA-wZnSeAR-48

2 – 12 μm HgCdTe ambient temperature photoelectromagnetic detector

PEM-10.6-2x2-PEM-SMA-wZnSeAR-48 is uncooled IR photovoltaic multiple junction HgCdTe detector based on photoelectromagnetic effect in the semiconductor – spatial separation of optically generated electrons and holes in the magnetic field. This device is designed for the maximum performance at 10.6 μm and especially useful as a large active area detector to detect CW and low frequency modulated radiation. This device is mounted in specialized package with incorporated magnetic circuit inside and SMA signal output connector. 3° wedged zinc selenide anti-reflection coated window prevents unwanted interference effects and protects against pollution.

Spectral response ($T_a = 20^\circ\text{C}$)

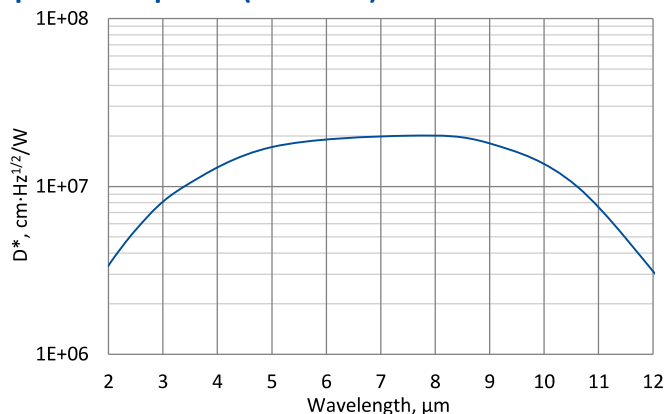

Exemplary spectral detectivity, the spectral response of delivered devices may differ.

Specification ($T_a = 20^\circ\text{C}$)

Parameter	Detector type
	PEM-10.6-2x2-PEM-SMA-wZnSeAR-48
Active element material	epitaxial HgCdTe heterostructure
Cut-on wavelength $\lambda_{\text{cut-on}}$ (10%), μm	≤ 2.0
Peak wavelength λ_{peak} , μm	8.5 ± 1.5
Optimum wavelength λ_{opt} , μm	10.6
Cut-off wavelength $\lambda_{\text{cut-off}}$ (10%), μm	≥ 12.0
Detectivity $D^*(\lambda_{\text{peak}})$, $\text{cm}\cdot\text{Hz}^{1/2}/\text{W}$	$\geq 2.0 \times 10^7$
Detectivity $D^*(\lambda_{\text{opt}})$, $\text{cm}\cdot\text{Hz}^{1/2}/\text{W}$	$\geq 1.0 \times 10^7$
Current responsivity $R_i(\lambda_{\text{peak}})$, A/W	≥ 0.002
Current responsivity $R_i(\lambda_{\text{opt}})$, A/W	≥ 0.001
Time constant τ , ns	≤ 1.2
Resistance R , Ω	≥ 40
Active area A , mm \times mm	2x2
Package	PEM with SMA connector
Acceptance angle Φ	$\sim 48^\circ$
Window	wedged zinc selenide AR coated (wZnSeAR)

Features

- Wide spectral range from 2 to 12 μm
- Large active area 2x2 mm²
- Wide dynamic range
- No bias required
- No flicker noise
- Short time constant ≤ 1.2 ns
- Radiation polarisation sensitive
- Convenient to use
- Quantity discounted price
- Fast delivery

Applications

- CO₂ laser (10.6 μm) measurements
- Laser power monitoring and control
- Laser beam profiling and positioning
- Laser calibration

Mechanical layout, mm

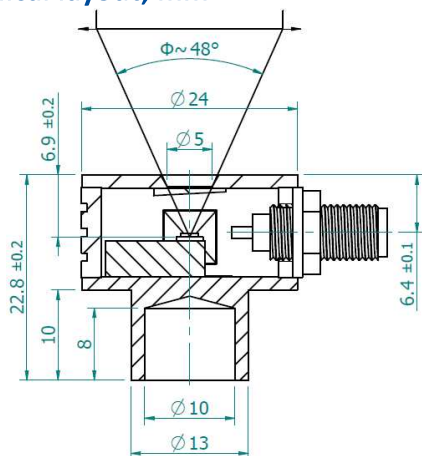

Φ – acceptance angle

Spectral transmission of wZnSeAR window (typical example)

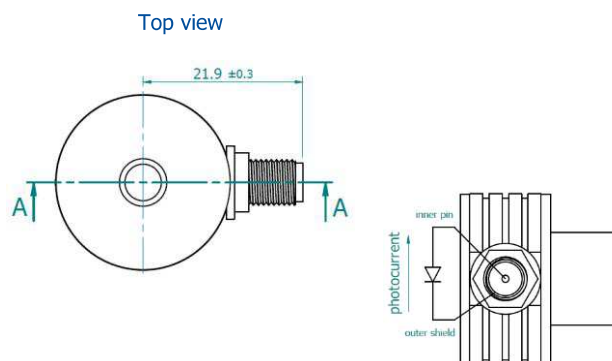
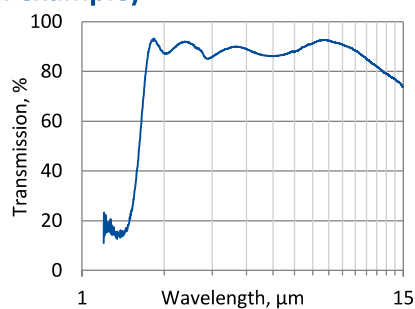

Included accessories

- SMA-BNC cable

Precautions for use and storage

- Operation in 10% to 80% humidity and -20°C to 30°C ambient temperature.
- Beam power limitations:
 - irradiance with CW or single pulse longer than 1 μs irradiance on the apparent optical active area must not exceed 100 W/cm^2 ,
 - irradiance of the pulse shorter than 1 μs must not exceed 1 MW/cm^2 .
- Storage in dark place with 10% to 90% humidity and -20°C to 50°C ambient temperature.