

PVI-8 SERIES

HgCdTe thermoelectrically cooled photovoltaic optically immersed infrared detectors

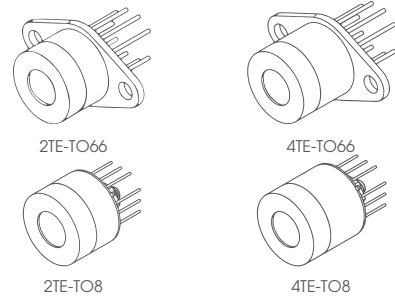

FEATURES

- Spectral range: 3.0 to 10.0 μm
- Back-side illuminated
- Unique immersion lens technology applied
- No minimum order quantity required

APPLICATIONS

- Gas detection, monitoring and analysis: CH_4 , H_2S , NO_2 , SO_x
- FTIR spectroscopy

SERIES DESCRIPTION

Detector symbol	Cooling (p. 191)	Temperature sensor (p. 192)	Optical area, A_o , mm \times mm	Optical immersion (p. 188)	Package	Acceptance angle, Φ , deg.	Window (p. 193)
PVI-2TE-8-1 \times 1-TO8-wZnSeAR-36	2TE $T_{\text{chip}} \approx 230\text{K}$	thermistor	1 \times 1	hyperhemisphere	TO8	~36	wZnSeAR (3 deg. zinc selenide, anti-reflection coating)
PVI-2TE-8-1 \times 1-TO66-wZnSeAR-36					TO66		
PVI-4TE-8-1 \times 1-TO8-wZnSeAR-36	4TE $T_{\text{chip}} \approx 198\text{K}$				TO8		
PVI-4TE-8-1 \times 1-TO66-wZnSeAR-36					TO66		

SPECIFICATION ($T_{\text{amb}} = 293\text{ K}$, $V_b = 0\text{ V}$)

Detector symbol	Cut-on wavelength (10%)	Peak wavelength	Specific wavelength	Cut-off wavelength (10%)	Detectivity		Current responsivity		Time constant	Dynamic resistance		
	$\lambda_{\text{cut-on}}$	λ_{peak}	λ_{spec}	$\lambda_{\text{cut-off}}$	$D^*(\lambda_{\text{peak}}, 20\text{kHz})$	$D^*(\lambda_{\text{spec}}, 20\text{kHz})$	$R_i(\lambda_{\text{peak}})$	$R_i(\lambda_{\text{spec}})$	τ	R_d		
	μm	μm	μm	μm	$\text{cm}\cdot\text{Hz}^{1/2}/\text{W}$	$\text{cm}\cdot\text{Hz}^{1/2}/\text{W}$	A/W	A/W	ns	Ω		
	Typ.	Typ.	Typ.	Typ.	Typ.	Min.	Typ.	Min.	Typ.	Typ.	Min.	Typ.
PVI-2TE-8-1 \times 1-TO8-wZnSeAR-36	3.0	6.0 \pm 1.0	8.9	8.9	4.0 \times 10 ⁹	2.0 \times 10 ⁹	1.6	0.8	1.0	45	30	40
PVI-2TE-8-1 \times 1-TO66-wZnSeAR-36												
PVI-4TE-8-1 \times 1-TO8-wZnSeAR-36		6.5 \pm 1.0	10.0	5.0 \times 10 ⁹	4.0 \times 10 ⁹	3.0	1.5	1.7	50		100	
PVI-4TE-8-1 \times 1-TO66-wZnSeAR-36												

SPECTRAL RESPONSE (Typ., $T_{amb} = 293\text{ K}$)

— PVI-2TE-8-1x1-TO8/TO66-wZnSeAR-36
 — PVI-4TE-8-1x1-TO8/TO66-wZnSeAR-36

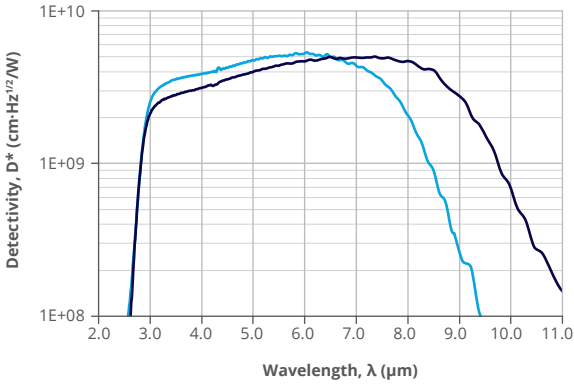

— PVI-2TE-8-1x1-TO8/TO66-wZnSeAR-36
 — PVI-4TE-8-1x1-TO8/TO66-wZnSeAR-36

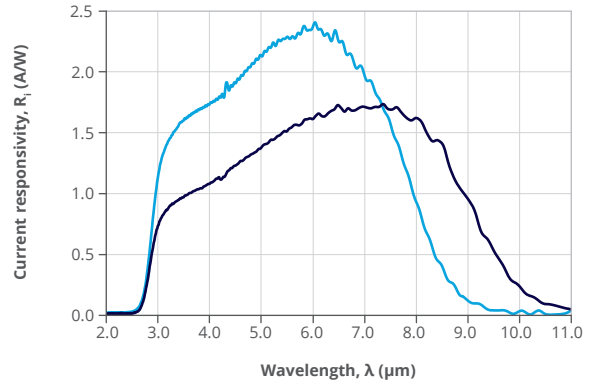

MECHANICAL LAYOUT AND PINOUT

- 2TE-TO8 package – Technical drawing (p. 204)
- 2TE-TO66 package – Technical drawing (p. 206)
- 4TE-TO8 package – Technical drawing (p. 210)
- 4TE-TO66 package – Technical drawing (p. 212)

RECOMMENDED AMPLIFIERS

Detector symbol	Amplifier type
PVI-2TE-8-1x1-TO8-wZnSeAR-36	AIP series (p. 126), PIP series (p. 129), MIP series (p. 132), SIP-TO8 series (p. 135), FIP series ^{*)} (p. 141)
PVI-4TE-8-1x1-TO8-wZnSeAR-36	

^{*)} Only for biased detectors

ABSOLUTE MAXIMUM RATINGS

Parameter	Test conditions/remarks	Value	Unit
Ambient operating temperature, T_{amb}	Operation at $T_{amb} > 30^{\circ}\text{C}$ may increase the active element temperature and reduce the performance of the detector below specified parameters	-20 to 30	$^{\circ}\text{C}$
Storage temperature, T_{stg}		-20 to 50	$^{\circ}\text{C}$
Soldering temperature	Within 5 s or less	≤ 300	$^{\circ}\text{C}$
Storage humidity	No dew condensation	10 to 90	%
Maximum incident optical power density	Continuous wave (CW) or single pulses $> 1\ \mu\text{s}$ duration	2.5	W/cm^2
	Single pulses $< 1\ \mu\text{s}$ duration	10	kW/cm^2
Maximum bias voltage, $V_{b\ max}$	No bias voltage needed	-	-
Maximum TEC voltage, $V_{TEC\ max}$	2TE	1.3	V
	4TE	8.3	
Maximum TEC current, $I_{TEC\ max}$	2TE	1.2	A
	4TE	0.4	

Stresses beyond those listed under absolute maximum ratings may cause permanent damage to the device. Constant or repeated exposure to absolute maximum rating conditions may affect the quality and reliability of the device.