

Thermopile Array TPL640

TPL640

High precise thermopile line 64 pixels with wide band filter for gas analysis and infrared spectroscopy.

Pixel	64	
Active Area per Pixel	0.45 x 1.5	mm ²
Pitch	0.5	mm
Number of Thermocouples per Pixel	30	
Pixel Resistance ³	8.5 ± 3.5	k
Relative Deviation of Resistance Between Adjacent Pixel	< 1/30	
Temperature Coefficient Resistance of Thermopile ²	typ. -0.4	%/K
Temperature Coefficient of Sensitivity ²	typ. -0.6	%/K
Noise Voltage ³	typ. 12	nV/Hz ^{1/2}
Filling Gas	Xenon	
DC Output Voltage ^{1,3,4}	typ. 4.0	mV
DC Sensitivity ^{1,3,4}	typ. 155	V/W
Time Constant $t_{(0-63\%)}$ ¹	typ. 110	ms
Specific Detectivity D* ^{1,3,4}	typ. 1.08 x 10 ⁹	cmHz ^{1/2} /W
Noise Equivalent Power ³	typ. 0.08	nW/Hz ^{1/2}
Crosstalk Between Adjacent Pixels	typ. 25	%
Filter	AR coated Ge Average %T: 90% from 2-	
Operation Temperature	-20 ... +70	°C
Mass	28	g

¹ on air without windows, Blackbody T=500 K; E=38 W/m²

² in temperature range from +25 to +70°C

³ at T_{amb}=25 °C

⁴ filling gas Xenon, assumed window transmission



MICRO-HYBRID



Bottom View

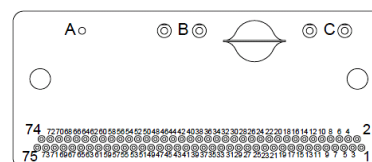

Pin Assignment:

Pin#	Assignments
1	NC
2	NC
3	NC
4	NC
5	NC
6	Pixel GND
7	Pixel 1
8	Pixel 2
:	:
69	Pixel 63
70	Pixel 64
71	Pixel GND
72	PTC+
73	PTC+
74	PTC-
75	PTC-
A	Case
B	NC
C	NC

Micro-Hybrid Electronic GmbH

**Heinrich-Hertz-Straße 8
D-07629 Hermsdorf**

**Tel.: +49 366 01 592 100
Fax: +49 366 01 592 110**

**Email: Infrared@micro-hybrid.de
Web: www.micro-hybrid.de**

LIVING MICROWORLDS.

Thermopile Array TPL640



Housin

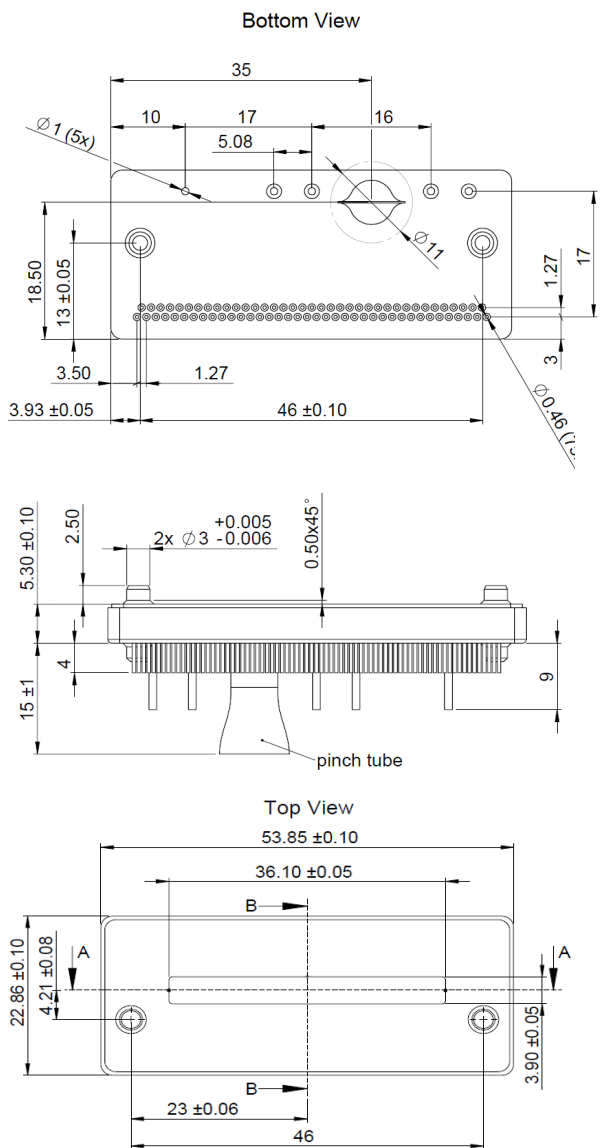

Order Information

Thermopile Array TPL640Xe-Ge 2-16 Art.-Nr. 7102.02-A.00

Micro-Hybrid Electronic GmbH

Heinrich-Hertz-Straße 8
D-07629 Hermsdorf

Tel.: +49 366 01 592 100
Fax: +49 366 01 592 110

Email: Infrared@micro-hybrid.de
Web: www.micro-hybrid.de

LIVING MICROWORLDS.